

Diversey

F&B

Membrane Cleaning

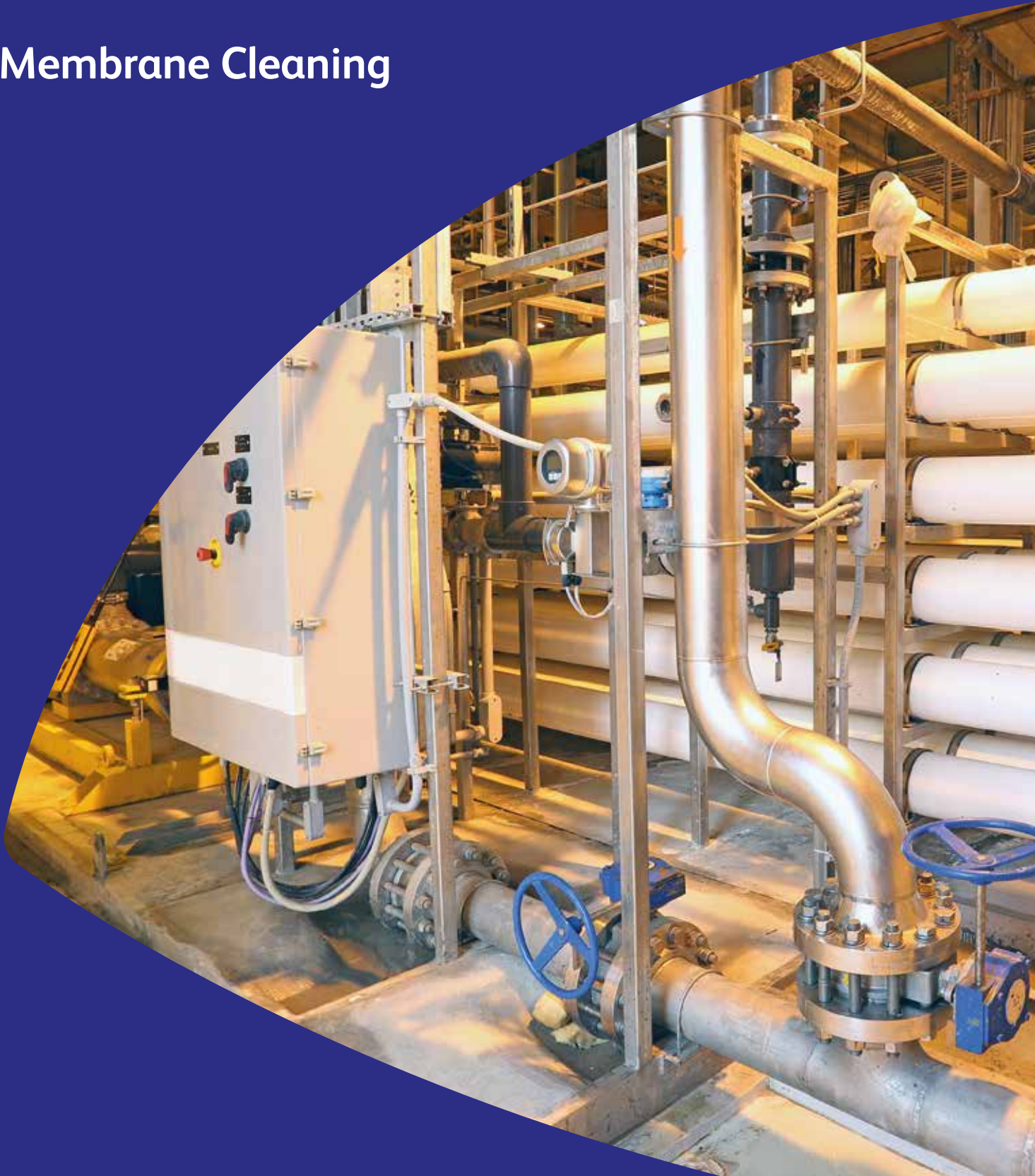

Membrane Cleaning - products and processes developed to increase operational efficiency

The Diversey® Divos program brings you:

- Maximized productivity
- Extended membrane life
- Product quality assurance
- Superior application support and service

Maximising Productivity

The Diversey Divos product portfolio, cleaning procedures and application expertise deliver superior results, increasing performance and processing efficiency for all membrane installations (MF, UF, NF, RO, Electrodialysis), in the food, beverage and pharmaceutical industries.

We provide customized programs that minimize cleaning times, lowering water, energy and other utility usage, while maximizing processing capacity and productivity.



Extended Membrane Life

The Divos range of products are tested and approved by installers and manufacturers to safeguard your membrane (tubular flow, ceramic plate and frame, spiral wound, hollow fibre, etc).

When used in combination with the correct maintenance regime and processing procedure, our customized cleaning programs ensure maximum process capacity and productivity while extending the life of your membrane.

Product Quality Assurance

Diversey cleaning and disinfection agents, application expertise and automatic dosing, monitoring and control systems, ensure the highest standards of hygiene are obtained on your membrane installations.

The Divos program protects the integrity of the most sensitive food and beverage, maximizing productivity and providing product quality assurance.

Superior Application Support and Service

Our representatives and application specialists will work closely with your managers and operators during auditing to understand your process and provide the best solution to meet your exact needs. Comprehensive on site support and training during start-up and on-going service, such as regular reviews and superior troubleshooting capability, ensure effective cost management and problem-free production is maintained.



Tailored to your individual needs

For all applications and requirements:

- Dairy (milk and whey filtration)
- Production of curd, cheese and ice cream)
- Breweries (sterile filtration, dealcoholisation)
- Wine and fruit juice (clarification and sterile filtration)
- Pharmaceuticals and Cosmetics
- Water and wastewater treatment

For the thorough cleaning of your Membrane systems:

- Pre-assembled membrane cleaner
 - alkaline
 - sour
 - enzymatically
 - oxidatively
- Disinfectant Cleaner

We design cleaning methods that fit to your requirements

We measure pressure and Temperature variations that can affect your membranes

We identify potential problems at source, because we understand how impurities can impact membranes efficiency

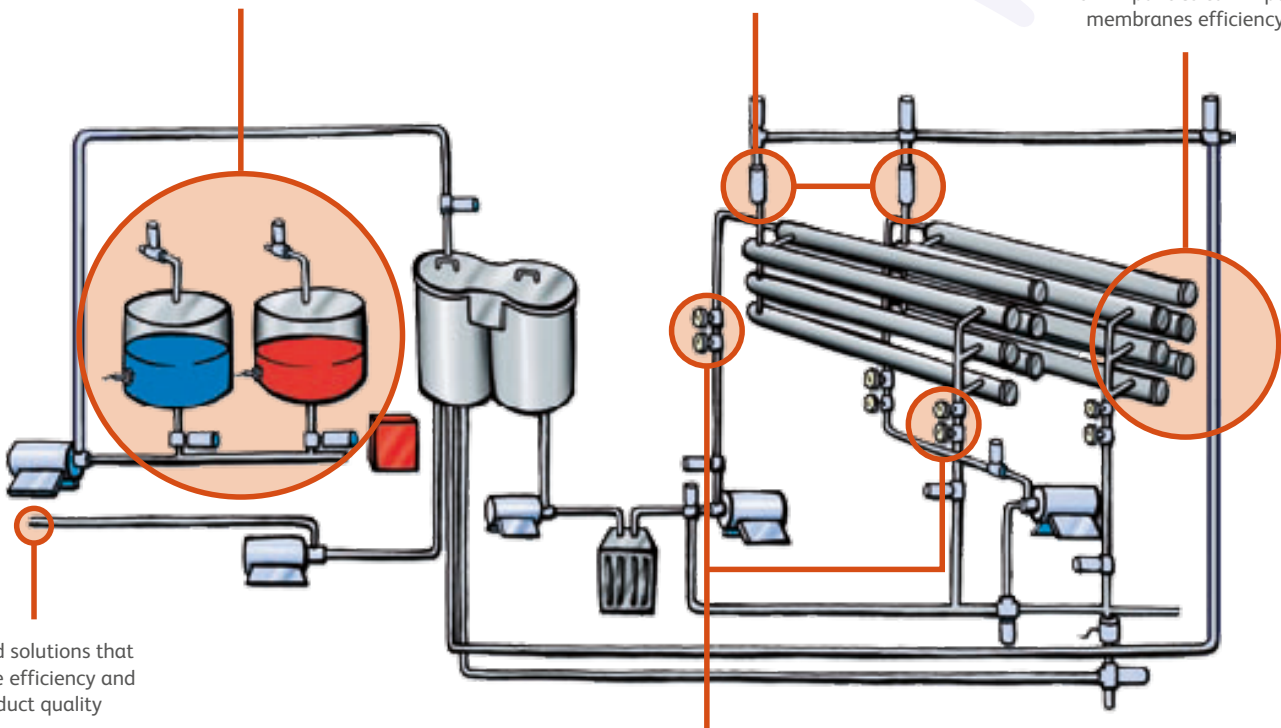

Tailored solutions that improve efficiency and product quality

We review the Water flow to determine whether your membranes really are clean



Diversey has been, and always will be, a pioneer and facilitator for life. We constantly deliver revolutionary cleaning and hygiene technologies that provide total confidence to our customers across all of our global sectors. Headquartered in Fort Mill, South Carolina, USA, Diversey employs approximately 9,000 people globally, generating net sales of approximately \$2.6 billion in 2017.

For more information, visit www.diversey.com or follow us on social media.

